

---

# KFR-72LW/88FZBpC Maintenance manual

Hisense Kelon Air-Conditioning Co., Ltd



Большая библиотека технической документации  
<http://splitoff.ru/tehn-doc.html>  
каталоги, инструкции, сервисные мануалы, схемы.

---

## Table of contents

一、MODEL AND BRAND-----	2
1.1 Model-----	2
1.2 Marketing Trademark-----	2
1.3 Short Selling-----	2
二、OUTLINES-----	3
三、FEATURES-----	4
3.1 Main functions-----	4
3.2 Technical Features-----	4
四、SPECIFICATIONS-----	6
五、ELECTRIC FUNCTIONS-----	7
5.1 Accessibility statement-----	7
5.2 Cooling-run mode-----	19
5.3 Heating-run mode-----	10
5.4 Dehumidifying mode-----	11
5.5 Air blowing mode-----	11
5.6 Dual-mode-----	12
六、ELECTRICAL DATA-----	13
6.1 Electric Wiring Diagrams-----	13
6.2 Refrigerant Flow Diagram-----	15
6.3 System pressure diagram-----	15
6.4 Air-conditioning Appearance Dimension Drawing-----	17
七、AFTER SERVICE-----	19
7.1 Trouble List-----	19
7.2 Parts List-----	21
7.3 Appendix: Specifications of components-----	26
7.4 Failure Analysis And Checking Flowcharts-----	32

---

## **一、 MODEL AND BRAND**

**1.1 Model: KFR-60LW/88FZBpC.**

**1.2 Marketing Trademark: Hisense Trademarks.**

**1.3 Short Selling: Frequency And Energy Saving.**

---

## 二、 OUTLINES

### 2.1 INDOOR



### 2.2 OUTDOOR



### 2.3 REMOTE



---

### 三、 FEATURES:

1. DC inverter and Energy-saving environmental protection;
2. Large heating capacity;
3. Auxiliary heating design;
4. Voice function;
5. Ionic air purification technology;
6. Design of the wind on three sides
7. Large-size LED screen, with adjustable brightness feature;
8. Color trims, with the color change control;
9. Touch keys, Polyphonic Ringtones turning on or off;
10. Sliding Mechanism Design; The upper panel with a motion mechanism, slide up when heating, And the wind out of the central. However, the upper panel is still and the wind out of the top when cooling. The wind out of the central when heating and out of the top when cooling, which is more conducive to hot and cold air convection indoor, and improve the efficiency of heat exchange.

#### 3.1 Main functions

##### 3.1.1 Complete functions

Cooling, heating, dehumidification, automatic, blasting and so on. Various models are complete and can realize various functions.

##### 3.1.2 Touch-screen

Through the touch-screen, can intelligently adjust various refrigeration, heating and other functions, as well as wind speed, temperature and other parameters.

##### 3.1.3 Ultra-Low Noise

Indoor use the three sides inlet means of both sides and the bottom, Optimization duct design, Quiet running noise.

##### 3.1.4 Ion Purification

Efficient cold plasma can effectively remove the harmful substances indoors.

##### 3.1.5 Sliding panel Features

When heating, the upper panel slides into the top and the middle baffle open. When cooling or off, the upper panel slides into the bottom and Covers the middle baffle, for beautiful and generous.

#### 3.2 Technical Features

##### 3.2.1 Characteristics of the circuits:

①Compressor Drivers use single-supply and low-cost IPM module program, and improved system integration and reliability.②Compressor drive circuits use no optocoupler and non-isolated driver program.

③System control and module driver are separated control, use asynchronous communication mode for communication.

---

④Using 180-degree sine wave drive program, improve the system vibration and noise performance and energy efficiency while broadening the scope of the system ability.

⑤Using a new generation of higher reliability PFC program, further improve the system reliability, and effectively improve the system's harmonic performance and energy efficiency at the same time.

⑥Outdoor switching power supply use new circuit, to reduce electromagnetic interference. Quad output switching power supply to the system control, AC and DC fan driver, PFC control circuit and module-driven electricity. In which system control and other three-way power supply is fully isolated and improve reliability.

⑦Touch keys design, to highlight user-friendly design.

⑧The dedicated display communications circuits, improved anti-jamming capability.

⑨Display and indoor power supply circuit are separated, and improved the reliability of the work.

⑩ Panel detection use photoelectric switch, and improved the reliability of detection.

### 3.2.2 System characteristics:

Using high-efficiency DC compressor match with the large area of condenser and evaporator, So air-conditioner could run stable and reliable, and energy-efficient.

### 3.2.3 Structural features:

Indoor structural elements is a new design

**Panels:** The upper panel is with a motion mechanism, which uses rack and pinion driving program. The upper panel slides up when heating up, and the center and both sides of the baffle open. However, the upper panel is still, and the top and both sides of the baffle open. The inlet use the sides and bottom inlet. The sides baffle use inside and outside two-baffle program. The outer baffle meet the requirements of design, while the inter baffle meet the requirements of outlet.

**Cabinet section:** As the first use the material of color-coated side, eliminating the need for spraying process. The first time using the overall style of the case structure, using a combination production technology of press and online bending, And using TOX riveting technology without rivets to rivete fan backplanes, improving their appearance and stability of the overall structure; Adopting a new duct design, plastic volute as well as the 380mm diameter fan to further reduce noise.

Outdoor cabinet universal W3C.

### 3.2.4 Additional features:

---High-efficiency compressor, High cooling capacity, Reliable and Durable.

#### 四、 SPECIFICATIONS

Model	KFR-60LW/88FZBpC				
Power Supply	220V~ / 50Hz	Power Phase	Single-phase	Climate Type	T1
Voltage Scope	175V ~ 250V ~	Connection	three-wire system	Waterproof grade	IPX4
Item		Units	Data		
Cooling	Rated Cooling Capacity (Minimum/Mid/ Max)	kW	6.0 (1.6 / 3.0 / 6.8)		
	Rated Input Power (Minimum/Mid/ Max)	kW	1.85 (0.45 / 0.79 / 2.40)		
	Rated Frequency (Minimum/Mid/ Max)	Hz	72 (18 / 33 / 87)		
	Operating frequency range: Minimum~ Max	Hz	25 ~ 87		
	Rated Input Current/Maximum Input Current	A	8.4 / 14.6		
	Maximum Input Power	kW	3.2		
	SEER/ APF [GB/T 7725-2004; GB 21455-2008]	W/W	4.33/ - ; 3.93/3		
	Dehumidification Capacity	L/h	2.0		
	AIR CIRCULATION	m3/h	900		
	Indoor Fan Speed: Low/Mid/High	r/min	260 / 320 / 380		
	Outdoor Fan Speed: Low/High	r/min	620 / 840		
	Indoor/Outdoor Running Current: (Test Use)	A	0.6(1±25%)/7.8(1±25%)		
Indoor/Outdoor Power Consumption: (Test Use)	kW	0.13(1±25%)/1.72(1±25%)			
Heating	Rated Heating Capacity (Minimum/Mid/ Max)	kW	7.3 (1.4 / 3.6 / 10.0)		
	Rated Input Power (Minimum/Mid/ Max)	kW	2.45 (0.45 / 0.97 / 3.20)		
	Rated Frequency (Minimum/Mid/ Max)	Hz	90 (18 / 45 / 105)		
	Operating frequency range: Minimum~ Max	Hz	25 ~ 105		
	Rated Heating Capacity/Rated input power of low-temperature heating	kW	6.5 / 2.80		
	Rated Input Current/Maximum Input Current	A	11.4 / 20.0		
	Maximum Input Power	kW	4.16		
	HSPF / APF [GB/T 7725-2004]	W/W	2.7 / 2.9		
	AIR CIRCULATION	m3/h	1000		
	Indoor Fan Speed: Low/Mid/High	r/min	260 / 320 / 380		
	Outdoor Fan speed: Low/High	r/min	620 / 840		
	Auxiliary heating device / Rated input power	W	RGL/1300		
Others	Temperature Range	°C	-7 ~ 43		
	Fusing current of main circuit	A	20		
	Refrigerant Code / Injection volume	kg	R410A/ 1.55		
	Indoor Noise: Minimum/Max	dB(A)	33 / 42		
	Outdoor Noise: Minimum/Max	dB(A)	48 / 52		
	Indoor Weight: Net Weight/GW	kg	41 / 52		
	Outdoor Weight: Net Weight/GW	kg	45 / 51		
	Indoor Size (length×Width×Height)	cm	53×32×185		
	Outdoor Size (length×Width×Height)	cm	90×35×64		
	Indoor Package Size (length×Width×Height)	cm	196×64×43		
	Outdoor Package Size (length×Width×Height)	cm	106×41×70		
	Compressor Manufacturers/Model/ Structure	—	GUANGDONG Meizhi /DA150S1C-20FZ/ Double Rotor		
	Wire: Diameter×Amount	mm2	2.5×4		
	Connecting pipe: Tubule/Tube Diameter	mm	12.7 / 6.35		
	Pipe: Random attachment length / Maximum	m	4.0 / 15		
	Throttle	—	Capillary		
	Parts Box No.	—	RZA-0-1030-002-DD-0		
Outdoor Mounting bracket component code	—	RZA-0-1040-015-XX-0			

---

## 五、 ELECTRIC FUNCTIONS

### 6. 1 Accessibility statement

#### 6.1.1 Failure codes self-test:

After continuously pressing "efficient" key on the remote four times in 10 seconds, the air-conditioner starts fault self-test. The fault flag should be checked by the display chip. If there is any failure, the fault codes are displayed in the location of the temperature value displayed, which flash 10 seconds or so, and other icons are properly displayed. If there is no failure, screen display reads "0." Then if there is display communication failure, it should also be displayed.

#### 6.1.2 Fixed-frequency mode:

The air-conditioner runs into the rating, after continuously receiving the operation of the efficient button on the remote 10 times. The air-conditioner runs according to the original settings state, frequency value is fixed, and the buzzer sounds five times.

#### 6.1.3 Panel buttons and remote control logic:

Indoor control change its own state after receiving the remote control signal, and the display contents are changed according to the settings change after display CPU receiving the signal from the indoor control board.

#### 6.1.4 Key Operation

**6.1.4.1 Switch Key:** ON or OFF.

**6.1.4.2 Mode Key:** Switching mode cycle.

**6.1.4.3 Speed Key:** Switching wind speed loop.

**6.1.4.4 Temperature+ Key:** Temperature increasing button, max 30.

**6.1.4.5 Temperature- Key:** Temperature decreasing button, minimum 16.

**6.1.4.6 Left-right Throttle Key:** Switching between sweeping and directional.

**6.1.4.7 Lock Key:** Entering lock state if no key operation about 1 minute, then invalid key.

**6.1.4.8 Unlock Key:** Hold down the switch key for 2 seconds or so, Keys to unlock state, Beeper.

#### 6.1.5 Operator-machine communication

The air conditioner has two sets of thermal sensor to detect room temperatures. One is equipped at remote controllers, and the other is equipped at the indoor air inlet. The default setting for room temperatures is subject to the detection by the remote controller. The remote controller detects the room temperature once every 20 seconds, and automatically transmits a signal at an interval of 3 minutes or when a change in the room temperature is detected. If the indoor control unit has not received a remote signal for more than 10 minutes, the control function will be automatically switched over to the thermal sensor on the indoor unit.



---

## **6.1.6 Timer function (24-hour timer)**

**6.1.6.1 Timer on:** When set to start in a time by the remote controller, the air conditioner starts in the timer on condition. When the set time is up, the air conditioner will turn on and operates in the preset conditions after receiving a signal from the remote controller. If the air conditioner has not received a signal from the remote controller when the set time is up, it will automatically start and operate in the preset conditions.

**6.1.6.2 Timer off:** When set to stop in a set time by the remote controller, the air conditioner will start in the timer off condition. When the set time is up, the air conditioner will turn off after receiving a signal from the remote controller. If the air conditioner has not received a signal from the remote controller when the set time is up, it will turn off automatically.

## **6.1.7 Sleep**

In the heating, cooling or dehumidifying mode, press the “Sleep” button on the remote controller to start or cancel the sleep function in turn, and at the same time the sleep icon on the display screen will be on or off accordingly. During the time of sleep mode, the set temperature will change automatically. The air conditioner will turn off and cancel the sleep function after the sleep function works for 8 hours.

## **6.1.8 High efficient run function**

In the heating (except for the single cooling unit), cooling or dehumidifying mode, it may be set for high efficient run with the indoor fan speed changed to the high efficient fan speed and the compressor operating at the highest frequency as available. It will restore to the previous run state after 15 minutes operation automatically.

## **6.1.9 Time control of Ionic Purifier**

The ionic purifiers are not always in work after starting the ion feature, but be automatically adjusted by the time (on or off).

This feature could not be started in the off state

## **6.1.10 Exchange of fresh air**

At any time (including shutdown) can start exchange of fresh air function. Shutdown initiative will cancel exchange of fresh air function, and exchange of fresh air function will electrify outdoor unit.

## **6.1.11 Mute**

After opening the mute function, indoor fan reduces speed, and outdoor compressor reduces the frequency.

Mute function is superior to ion purification

## **6.1.12 Switching temperature display**

Press the Temperature Switch key to switch indoor temperature, outdoor temperature and set temperature circle.

---

### **6.1.13 Energy-saving in use**

After entering the state of energy-saving in use, the current does not exceed X1 A, by adjusting the compressor operating frequency and limiting the maximum current of the compressor. And switch operation can not cancel this function.

### **6.1.14 Indoor Unit Error**

Grating errors, DC fan and communication failure between indoor and outdoor can lead to system downtime, but other errors can not. Report errors through indoor LED lights.

### **6.1.15 Throttle State**

**6.1.15.1 Left-right inlet:** Left-right inlets are positioned at the maximum position when open, completely shut down after shutdown, and are still in other time.

**6.1.15.2 Upper and lower damper blade:** Opening and closing will be conducted the largest location-based for the first time, and other control methods see the corresponding mode.

**6.1.15.3 Middle damper blades:** Opening and closing will be conducted the largest location-based for the first time, and other control methods see the corresponding mode.

**6.1.15.4** If shut down when the left throttle or intermediate damper in positioning (uninterruptible power shutdown), the leaves should be restored to the shutdown position when re-boot.

### **6.1.16 Automatic run mode**

According to the parameters such as the set temperature and room temperature, automatically determine the machine's operating mode

### **6.1. 17 cooling→heating and heating→cooling:**

**cooling→heating:** Compressor stops, 4-way valve is electrified after 50 seconds, the compressor opens after 3 minutes

**heating→cooling:** Compressor stops, 4-way valve is interrupted after 50 seconds, the compressor opens after 3 minutes

## **6.2 Cooling-run mode**

### **6.2.1 Indoor fan**

When the fan speed is set at the high, medium and low fan speeds, the fan runs at a preset speed. When the fan speed setting is automatic, the fan speed is set based on the difference in room temperatures.

When the fan speed setting is automatic, the fan speed is set based on the difference in room temperatures.

### **6.2.2 Throttle blade control**

#### **6.2.2.1 The blades of the left-right throttle outlet**

The blades of the left-right throttle are switched between fixed and swept according

---

to the remote.

#### **6.2.2.2 Top outlet**

The top throttle is fixed at the maximum position.

#### **6.2.3 Outdoor Fan**

The speed of outdoor fan is single-speed. The outdoor fan is controlled on an off according to outdoor ambient temperature.

#### **6.2.4 Prevention against condensation and insufficient heat exchange at the low indoor fan speed.**

When the indoor fan speed is set at the low fan speed, the compressor's power is restricted as in the low temperature cooling.

#### **6.2.5 4-way valve**

**State:** It is interrupted in cooling.

**Switchover:** When initially electrified for cooling, the 4-way valve is interrupted immediately.

**When the heating is changed to the cooling, it needs an interval of 50 seconds for the 4-way valve to change over from being electrified to being interrupted.**

### **6.3 Heating-run mode**

#### **6.3.1 Throttle blade control**

##### **6.3.1.1 The blades of the left-right throttle outlet**

The blades of the left-right throttle are switched between fixed and swept according to the remote.

The left-right throttle is targeted to the minimum position in cold air prevention mode.

##### **6.3.1.2 The blades of the top throttle control**

The top throttle is fixed at the minimum position (the minimum position of 88 series Floor Type Air-Conditioner is 0, that is, is closed).

The top throttle is fixed at the maximum position in cold air prevention mode.

#### **6.3.2 Indoor fan**

As cooling-run mode except for cold air prevention mode and defrosting mode ( $T = T_{set} - T_{indoor\ ambient}$ ).

#### **6.3.3 Cold air prevention**

If the outlet wind temperature of the indoor is too low in heating, Users can feel the feeling of chilling by cold air. Cold air prevention function is that Controls the fan speed according to the indoor coil temperature, and regulates the air supply, thereby, Maintain indoor air supply at an appropriate temperature range, and improve the air-conditioned comfort.

When the coil temperature reaches 20 °C after starting, indoor fan runs by the breeze. Then control indoor fan speed to increase progressively according to the indoor coil temperature. When the coil temperature reaches 38 °C, the indoor fan

---

runs by the setting speed.

After stable operating, if the indoor coil temperature  $p < 32 \text{ }^\circ\text{C}$ , the fan speed  $s$  gradually reduced.

Under any circumstances, if the setting speed is less than the current speed, runs by the setting speed.

### 6.3.4 Outdoor fan

The outdoor fan speeds are divided into three levels which can be changed over according to outdoor ambient temperatures.

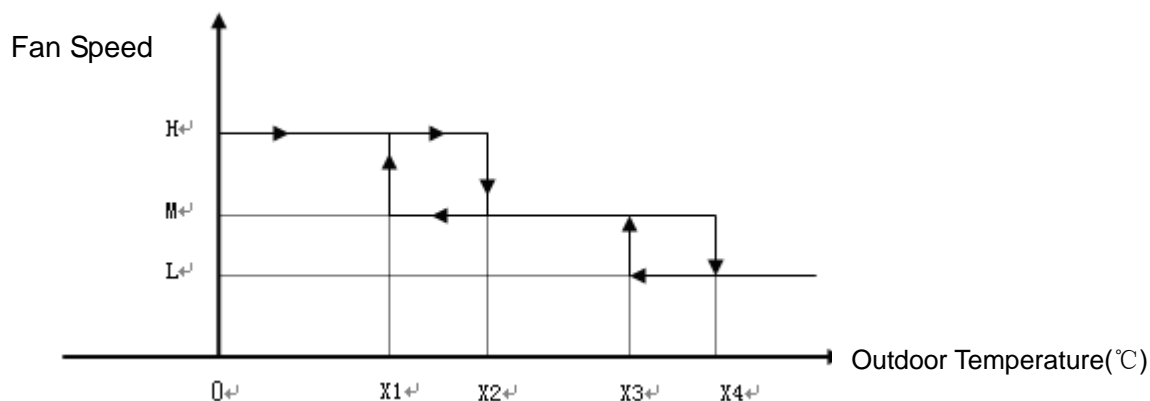

### 6.3.5 4-way valve

**State:** It is electrified in heating.

**Switchover:** When initially electrified for heating, the 4-way valve is electrified immediately.

In the change from cooling to heating, it needs an interval of 50 seconds for the 4-way valve to change over from being interrupted to being electrified.

### 6.3.6 Auxiliary Heating

The unit automatically starts Auxiliary Heating or stops according to the temperatures of indoor and outdoor.

## 6.4 Dehumidifying mode

### 6.4.1 Dehumidifying mode control

Dehumidifying mode is started or stopped according to the difference between the setting temperature and the indoor environment temperature.

## 6.5 Air blowing mode

**6.5.1 The outdoor unit does not work.**

**6.5.2 The indoor unit runs in the cooling mode. When being auto, the fan speed is selected at medium speed.**

**6.5.3 The blades of the indoor throttle control**

As cooling mode.

---

## **6.6 Dual-mode**

**6.6.1 Comfort mode is separated cooling comfort mode and heating comfort mode.**

**6.6.2 Energy saving mode is separated cooling energy saving mode and heating energy saving mode.**

六、 ELECTRICAL DATA  
 7.1 Electric Wiring Diagrams  
 7.1.1 Indoor

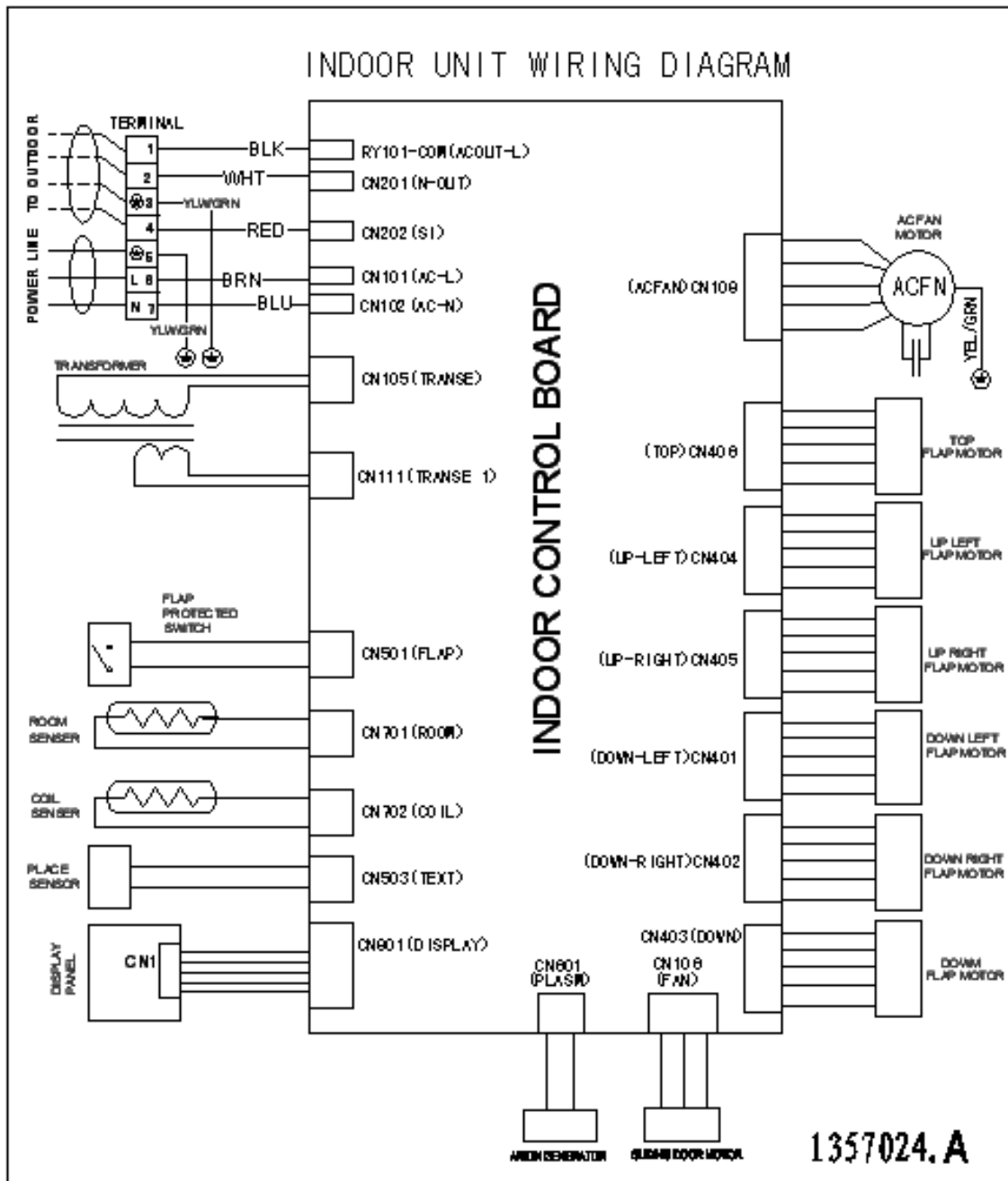

7.

## 7.1.2 Outdoor

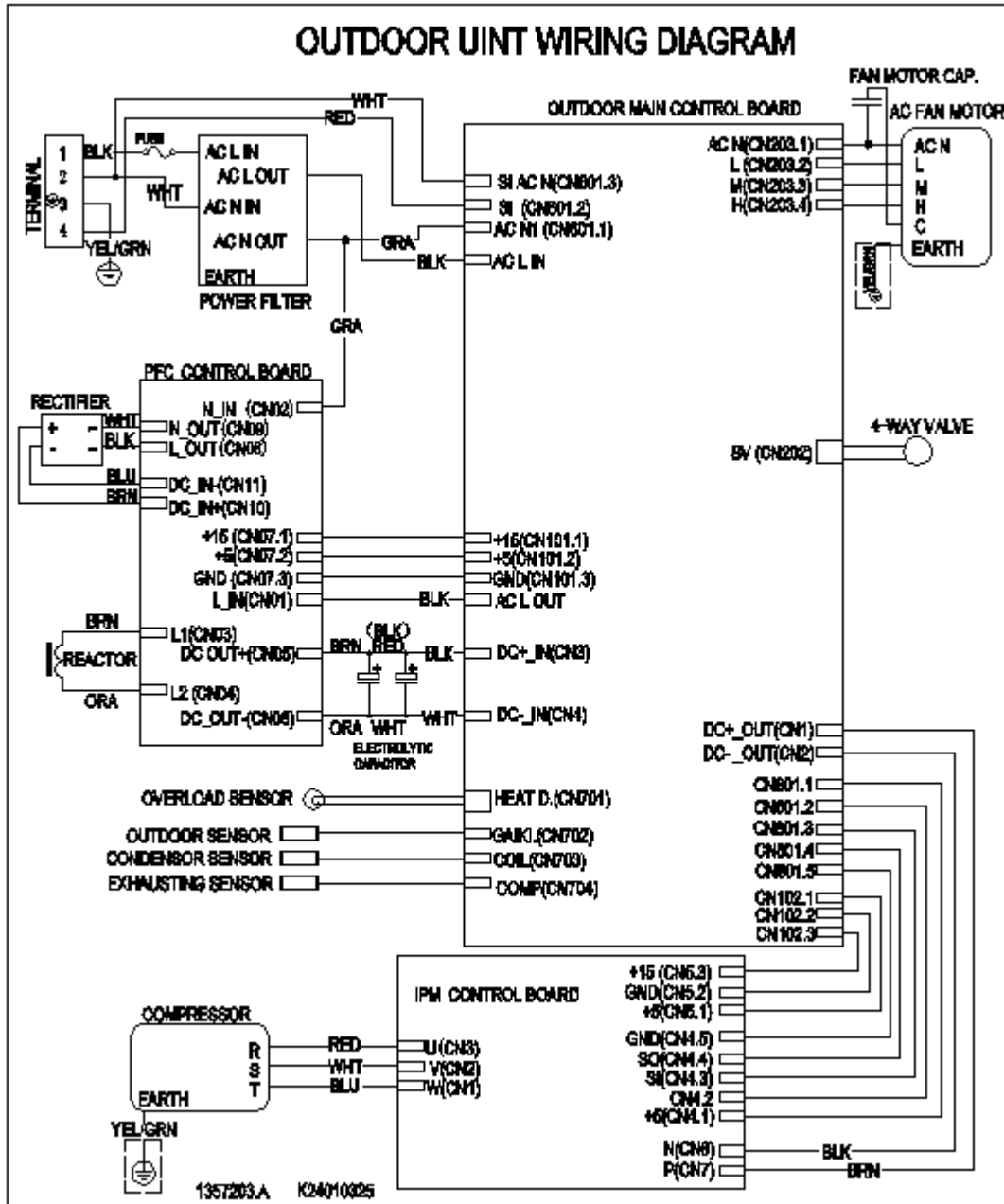

## 7.2 Refrigerant Flow Diagram

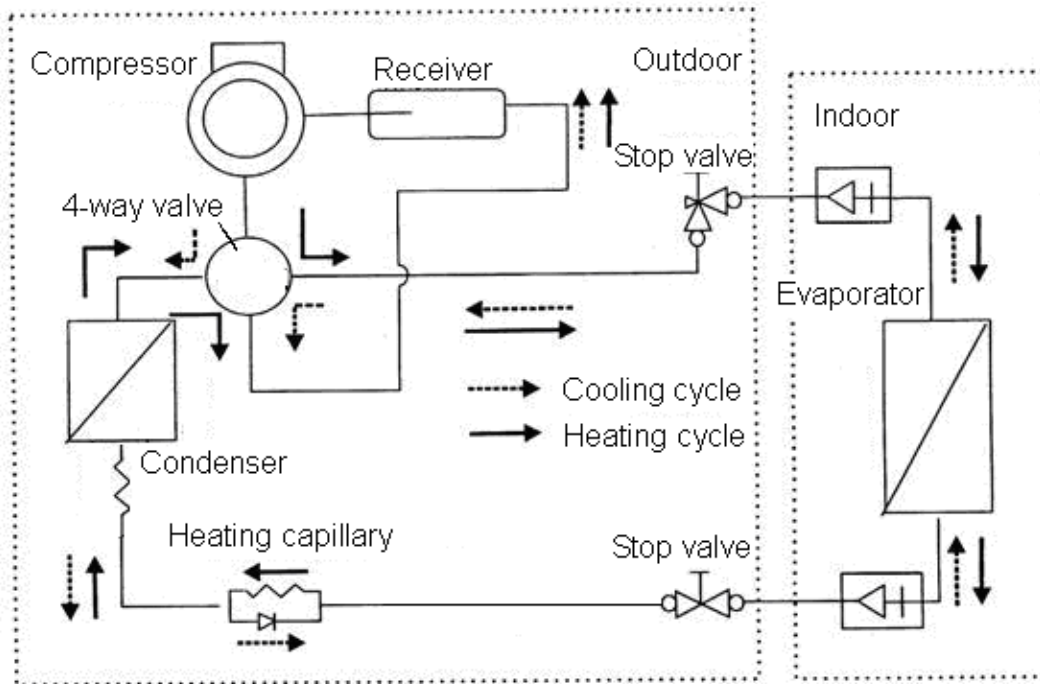

## 7.3 System pressure diagram

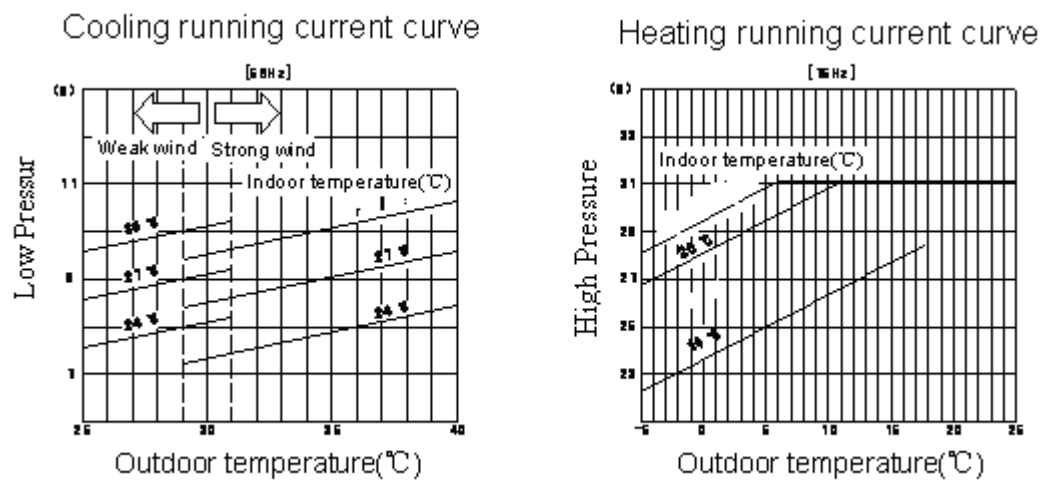



Cooling running current curve  
(Indoor Relative Humidity:46% Wind speed: strong)

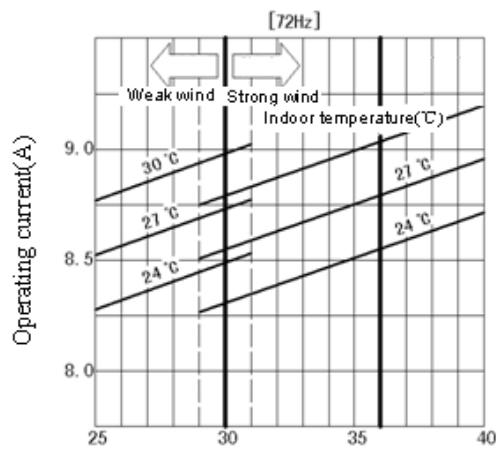

Heating running current curve  
(Indoor Relative Humidity:60% Wind speed: strong)

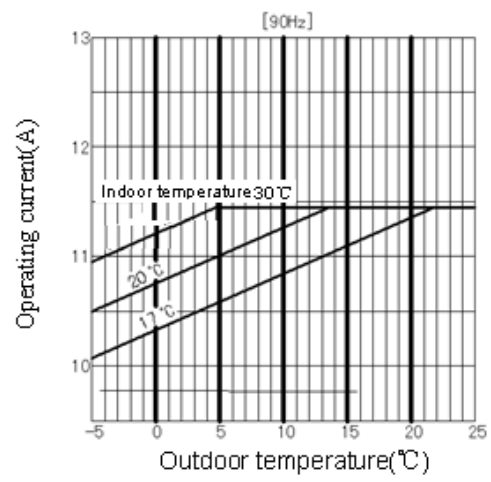

## 7.4 Air-conditioning Appearance Dimension Drawing

### 1. Indoor

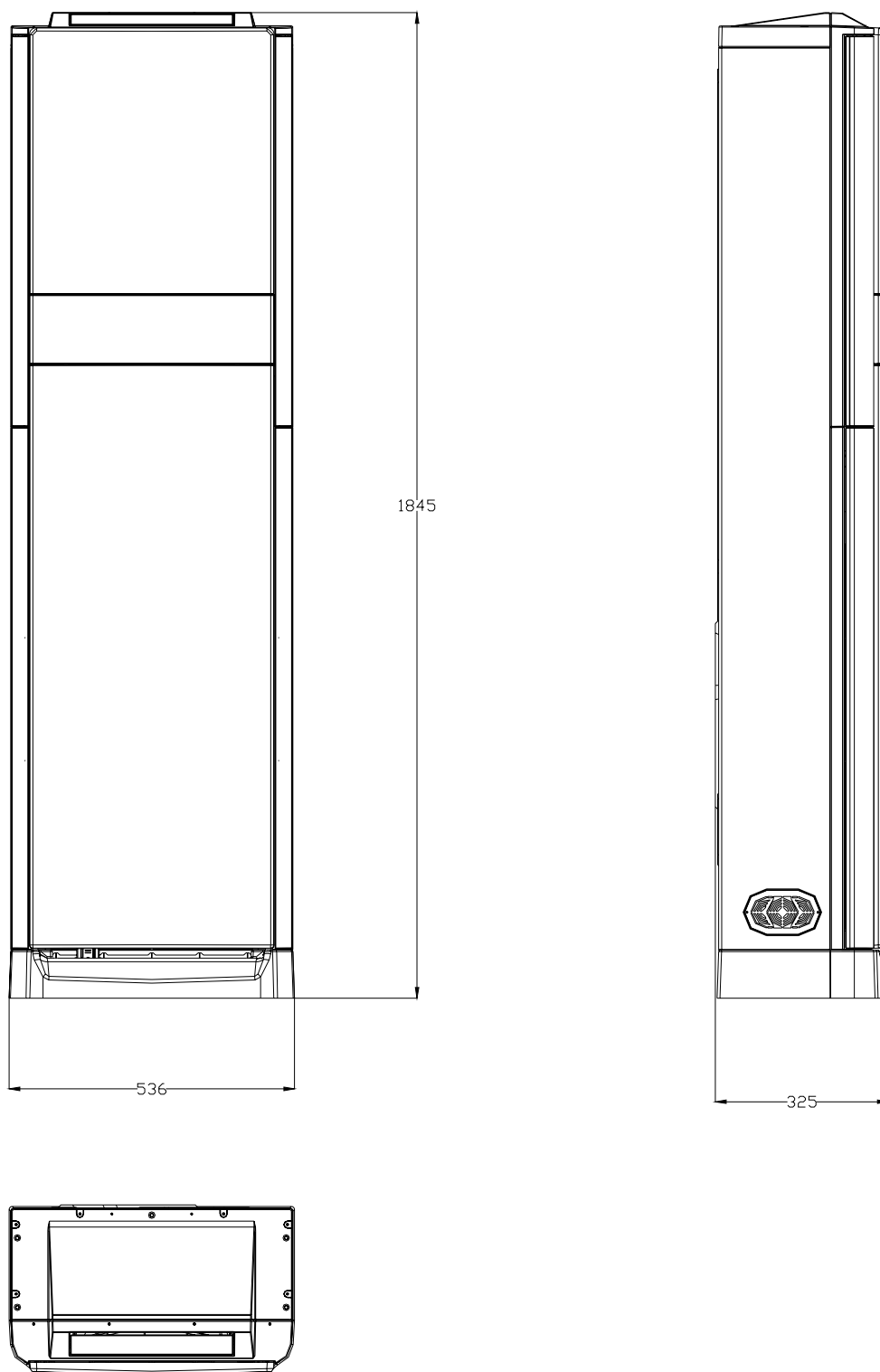

## 2. Outdoor

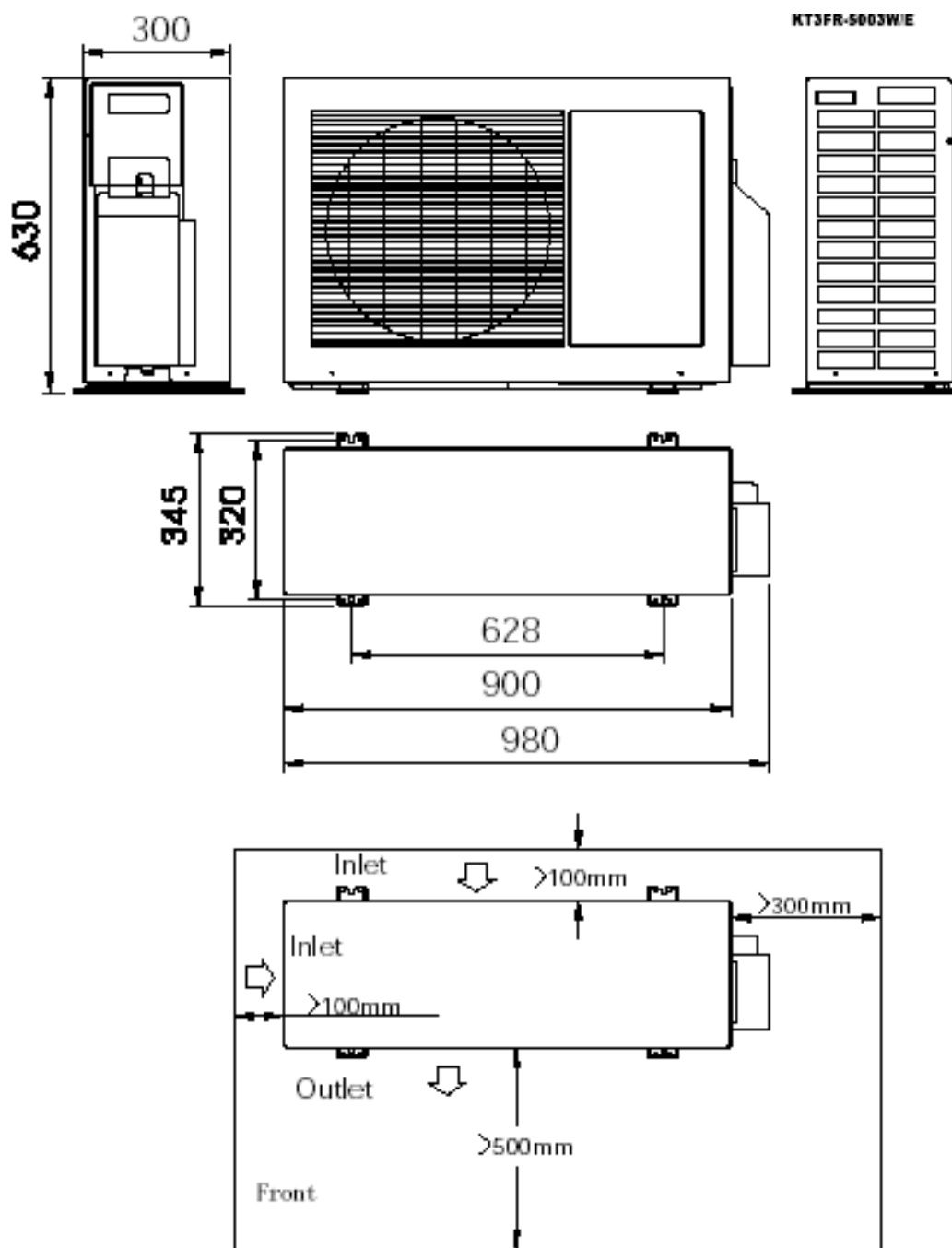

## 七、 AFTER SERVICE

### 8.1 Trouble List

**8.1.1** When the compressor is in operation, The 3 LED indicator lights on the control panel of the outdoor unit indicates the causes of the restriction on the compressor's current operating frequency

Symbols for indicator light: ★: ON O: flashing ×: OFF				
	LED1	LED2	LED3	The cause of the restriction on the compressor's current operating frequency
1	O	O	O	Normal frequency ascent and descent with no restriction on the frequency
2	×	×	★	Frequency descent or restriction on frequency ascent caused by over current
3	×	★	★	Frequency descent or restriction on frequency ascent caused by anti-freeze in cooling or overload control in heating
4	★	×	★	Frequency descent or restriction on frequency ascent caused by too high compressor discharge temperature
5	×	★	×	Restriction on maximum operation operating frequency caused by too low voltage on the supply circuit
6	★	★	★	Operating at a fixed frequency (when in a capacity measurement or forced operation at a fixed frequency.)
7	×	★	O	Outdoor anti-overload protection Frequency descent or restriction on frequency

**8.1.2** When the compressor is interrupted, the outdoor LEDs are used to indicate the troubles listed below:

Symbols for indicator light: ★: ON O: flashing ×: OFF				
	LED1	LED2	LED3	Troubles
1	×	×	×	Normal
2	×	×	★	Room temperature sensor short-circuited, open circuited or the corresponding test circuit in trouble
3	×	★	×	Indoor heat exchanger temperature sensor short-circuited, open circuited or the corresponding test circuit in trouble
4	★	×	×	Compressor temperature sensor short-circuited, open circuited or the corresponding test circuit in trouble
5	★	×	★	Outdoor heat exchanger temperature sensor short-circuited, open circuited or the corresponding test circuit in trouble
6	★	★	×	Outdoor atmosphere temperature sensor short-circuited, open circuited or the corresponding test circuit in trouble
7	O	★	×	CT (mutual inductance coil) short circuit, open circuit or detection circuit fault
8	O	×	★	Outdoor voltage detection circuit fault
9	×	×	O	Signal communication abnormal (indoor – outdoor)
10	×	O	×	Power module (IPM) protection
11	★	O	★	Maximum current control
12	★	O	×	Current overload control
13	×	O	★	Compressor discharge temperature too high
14	★	★	O	Over and under-voltage control
15	★	O	O	Outdoor ambient temperature protection (only KFR-2820GW/BP)
16				
17	O	★	★	Refrigerant leak (not yet available)
18	×	★	O	Compressor housing temperature too high
19	★	★	★	Outdoor memory in trouble
20	×	O	O	Indoor fan motor in trouble

21	×	★	★	With the drive module communication failure
22				
23	○	×	○	DC compressor out of step
24	○	○	×	DC compressor fails to start
25	○	○	★	DC Fan Trouble
26	○	★	○	Outdoor DC compressor heating state

### 8.1.3 Indication by the indoor unit (on)

Fault code	Power	Running	Efficient	Fault code	Power	Running	Efficient
0	★	★	★or×	20			
1	○	★	★	31	×	★	○
2	○	★	×				
				33	★	○	○
4	★	○	★	34	×	○	○
5	★	○	×	35			
6	×	○	×	36	○	★	○
				37	○	×	○
8	★	×	○	38	○	○	×
9	×	×	○	39	○	○	★
10				40	○	○	○
11	○	×	×				
13	○	×	★				
14	★	★	○				
15	×	○	★				

### 8.1.4 Indication by the indoor unit, Press the high power for 4 times in 10 seconds and the trouble codes listed below will be displayed as follows:

0	No trouble	20	Outdoor DC fan failure
1	Outdoor coil temperature sensor in trouble	21	Outdoor cooling coil anti-overload protection
2	Compressor temperature sensor in trouble	22	Compressor Pre-heating condition
3	Voltage transformer in trouble	31	Key AD value converted failure
4	Current transformer in trouble	33	Room temperature sensor in trouble
5	IPM module protection	34	Indoor coil temperature sensor in trouble
6	Over and under-voltage control	35	
7	Communication trouble	36	Communication between the indoor and outdoor in trouble
8	Current overload control	37	Indoor and wired remote communication failure
9	Maximum current control	38	Indoor EE Fault
10	4-way valve changeover abnormal	39	Indoor fan motor operation abnormal
11	Outdoor EEPROM in trouble	40	Grid protection alarm (cabinet type)
12	Compressor exhaust temperature too high control		
13	Outdoor ambient temperature sensor in trouble		
14	Compressor housing temperature control		
15	IPM module protection		
16	Anti-freeze or overload control		
17			
18	DC compressor fails to start		
19	DC compressor out of step		

## 8.2 Parts List and Details

### 8.2.1 Outdoor:

#### 8.2.1.1 Parts:

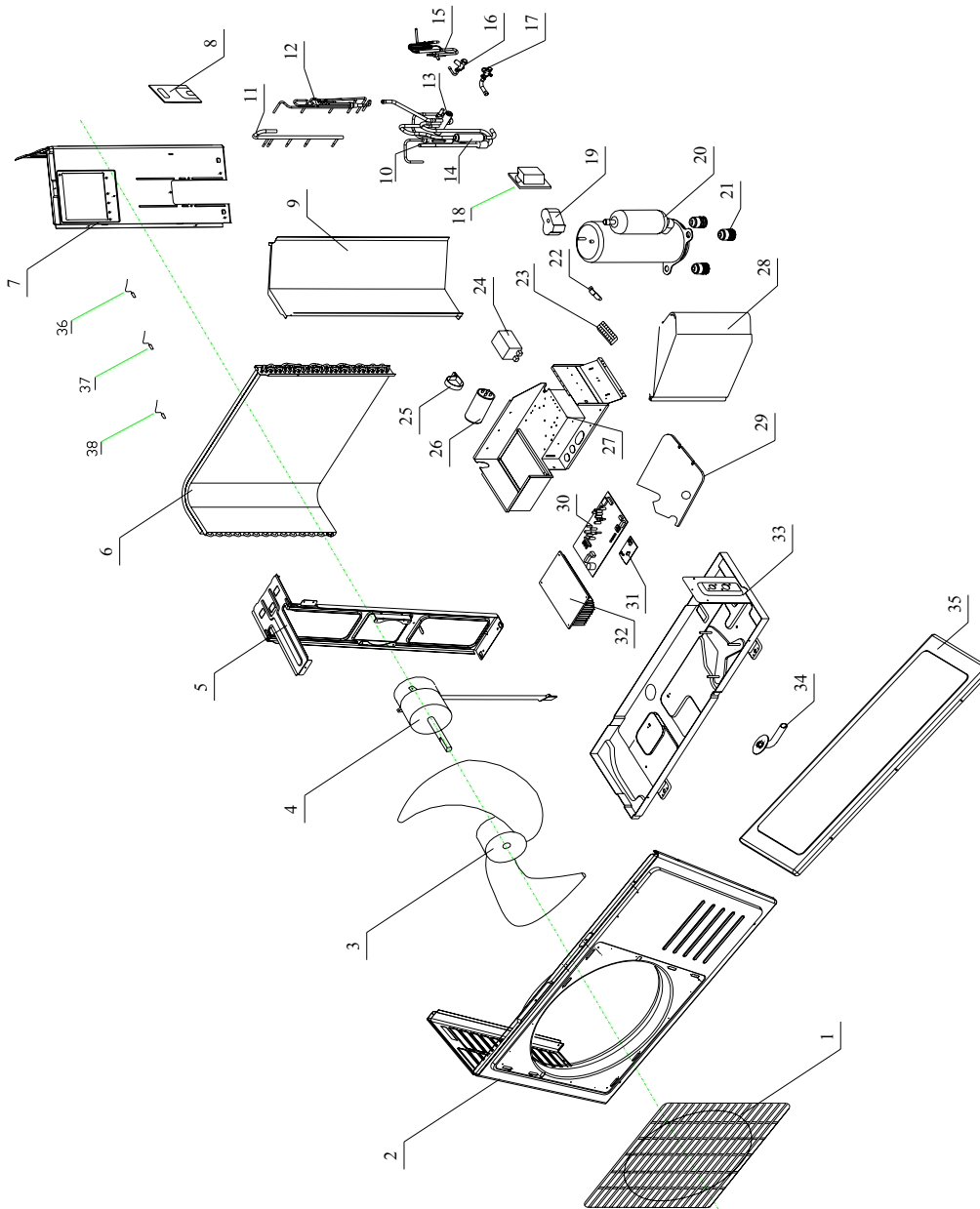

**8.2.1.2 LIST:**

KFR-50W/88FZBp Parts List				
No.	Part No.	Description	Q'ty	Notes
1	RZA-0-1321-003-XX-0	FAN GUARD	1	
2	K31470066	FRONT PANEL	1	
3	K38310006	AXIAL FAN	1	
4	K1B310044	FAN MOTOR ASSY	1	
5	K331F0028	FAN SUPPORTER	1	
6	K37330155	CONDENSER ASSY	1	
7	K31220012	SIDE PANEL ASSY	1	
8	RZA-0-5302-003-XX-1	SIDE COVER ASSY	1	
9	K33660017	CLAPBOARD	1	
10	1318997	MUFFLER	1	
11	1335437	IMPORT TUBE ASSEMBLY	1	
12	1335501	EXPORT TUBE ASSEMBLY	1	
13	1301088	4-WAY VALVE	1	
14	1203416	MUFFLER	1	
15	1335556	CAPILLARY COMPONENTS	1	
16	1204863	STOP VALVE	1	
17	1332842	STOP VALVE	1	
18	K33AB0008	NOISE DEFENING COVER	1	
19	1204841	COMPRESSORS BOX	1	
20	1339309	COMPRESSORS	1	
21	1204988	COMPRESSORS RUBBER	3	
22	RZA-2-5304-003-XX-1	CLIP ASSY	1	
23	1201068	TERMINAL PANEL	1	
24	1205770	FILTER	1	
25	RZA-2-5301-002-XX-0	CLAMP	1	
26	1304655	ELECTROLYTIC CAPACITOR	1	
27	RZA-0-5301-064-XX-5	ELECTRICAL BOX	1	
28	RZA-2-2476-196-XX-0	NOISE DEFENING COVER	1	
29	K33AB0034	NOISE DEFENING COVER	1	
30	1306563	POWER BOARD ASSY	1	
31	1327830	DRIVER BOARD	1	
32	K33AE0004	RADIATOR	1	
33	K31120018	BASE ASSY	1	
34	852-2-2228-132-02-0	DRAINAGE HOSE	1	
35	K338A0022	COVER ASSY	1	
36	1201219	DISCHARGE TEMPERATURE SENSOR	1	
37	1326145	AMBIENT TEMPERATURE SENSOR	1	
38	1201221	COIL TEMPERATURE SENSOR	1	

## 8.2.2 Indoor:

### 8.2.2.1 Parts:

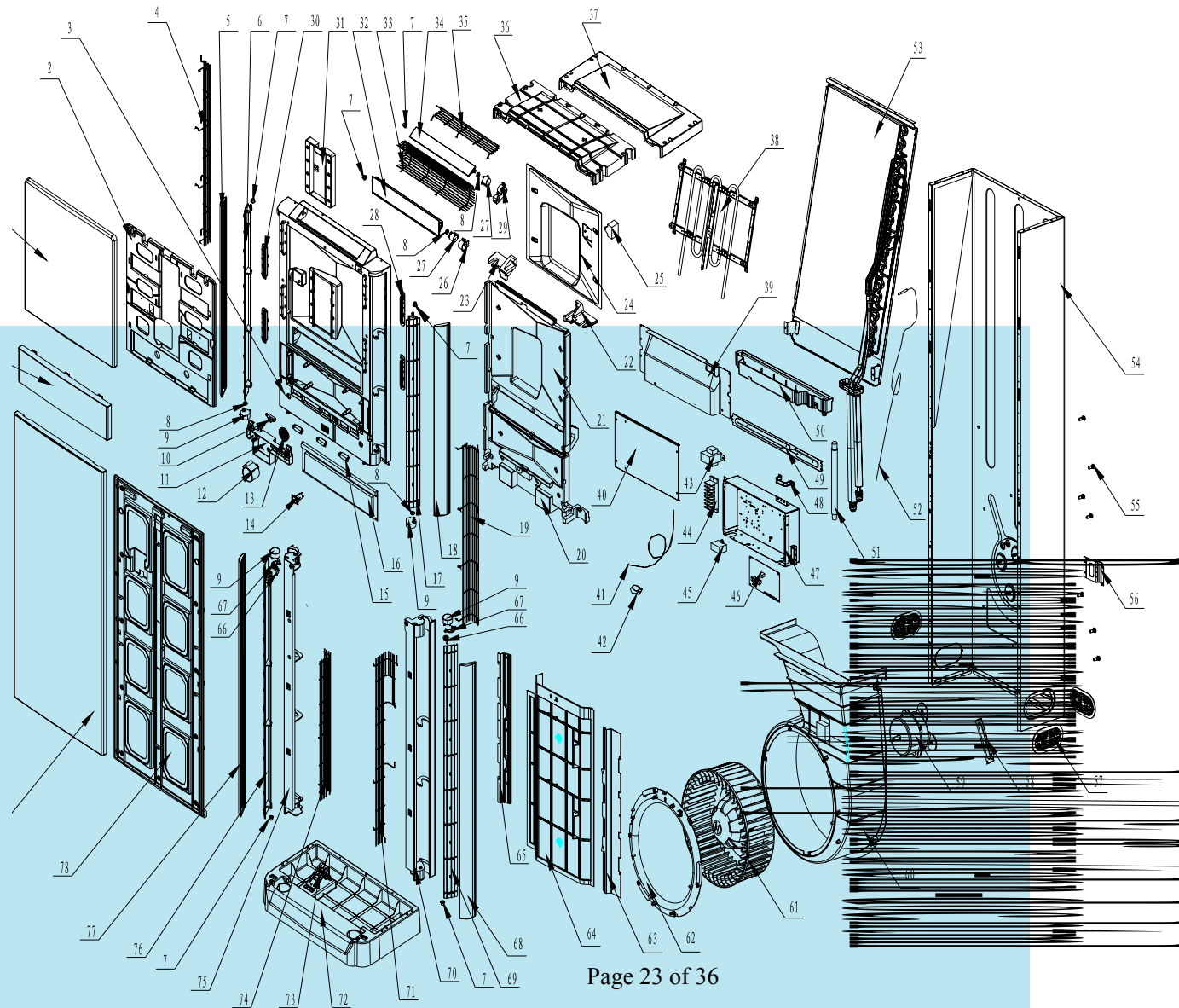



### 8.2.2.2 LIST:

No.	Part No.	Description	Q'ty	Notes
1	8007080	Upper panel	1	
2	8007081	Upper panel	1	
3	8007082	Outlet	1	
4	8007422	Care Net	1	
5	8005218	Vertical Wind Plate	1	
6	8007084	Vertical Wind Plate	1	
7	1205536	Original sleeve	6	RZA-2-1514-065-XX-0
8	8005279	Short sleeve	4	
9	1335589	Stepper Motor	4	
10	1331700	Photoelectric Switch	1	
11	8007100	Support Parts	1	
12	1331460	Synchronous motor	1	
13	1248737	Gear	1	
14	1304986	Door Switches	1	RZA-0-5319-010-XX-0
15	1202481	Magnet Components	3	RZA-0-2265-001-01-0
16	1338557	display panel	1	
17	8007085	Vertical Wind Plate	1	
18	8007109	Vertical Wind Plate	1	
19	8007423	Care Net	1	
20	8007481	Foam pieces	1	
21	8007480	Foam pieces	1	
22	8007580	Foam pieces	1	
23	8007581	Foam pieces	1	
24	1338997	Seal plate parts	1	
25	1327702	Cold Plasma	1	
26	8007102	Motor guard	1	
27	1314556	Stepper Motor	1	
28	8007111	Right rail	2	
29	8005281	Motor Cover	1	
30	8007105	Left rail	2	
31	8007419	Rack	1	
32	8007086	Transverse Wind Plate	1	
33	8007421	Care Net	1	
34	8007083	Transverse Wind Plate	1	
35	8007420	Care Net	1	
36	8007479	Foam pieces	1	
37	8007093	Cover	1	
38	1335521	Heater Components	1	

39	1335565	Seal plate parts	1	Middle shield+ Sponge
40	8005554	Electrical lid	1	
41	1326150	Temperature device	1	Temperature
42	1318746	Clamp	1	Fixed Temperature Sensor
43	1341826	Transformers	1	
44	1201073	TERMINAL PANEL	1	
45	1202889	Fan Capacitor	1	
46	1356020	Control Board	1	
47	1331981	Electric Box Components	1	
48	8005556	Support Parts	1	Pipe Clamp
49	8005555	Support Parts	1	Support Box
50	8006879	Water tray	1	
51	1227302	Drain	1	
52	1205710	Coil temperature sensor	1	Coil
53		Evaporator Components	1	
54	1337534	Side components	1	Side+Sponge+Support Parts
55	1205320	Clasp	7	Fixed scroll
56	8007384	Support Parts	1	Pipe Clamp
57	1308927	Cover	3	
58	1335430	Support Parts	1	Electrical Line Plate+Sponge
59	1333210	Fan Motor	1	
60	1331818	Fan scroll Parts	1	Scroll+Sponge
61	1332202	Centrifugal fan	1	Green
62	8005548	Deflector	1	Inlet mask ring
63	8005549	Rail	1	Right rail
64	8007382	Filter Parts	1	Light green
65	1339652	Support Parts	1	Left rail+Clamp
66	8007104	Sleeve	2	
67	8007107	Support Parts	2	
68	8007110	Vertical Wind Plate	1	
69	8007092	Vertical Wind Plate	1	
70	8007090	Inlet	1	
71	8007423	Care Net	1	
72	8005217	Base	1	
73	1339010	Mounting plate parts	1	
74	8007424	Care Net	1	
75	8007089	Inlet	1	
76	8007091	Vertical Wind Plate	1	
77	8007099	Vertical Wind Plate	1	
78	8007088	Bottom Panel	1	
79	8007087	Bottom Panel	1	
80	1335573	Panel components	1	

## 8.3 Appendix: Specifications of components

### 1. Outdoor fan (YDK55-6I-8)

#### ① Winding Resistance (20°C)

Coil	Parameters	Permissible range
W-M	185Ω	±15%
W-A	200Ω	±15%
C	3uF/450V	

#### ② Electrical wiring

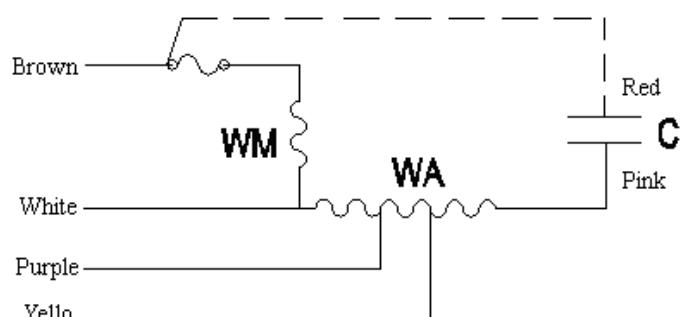

### 2. Indoor fan(YDK50-8-24)

#### ① Coil Resistance (20°C)

Coil	Parameters	Permissible range
W-M	105Ω	±15%
W-A	157Ω	±15%
C	4uF/450V	

#### ② Electrical wiring

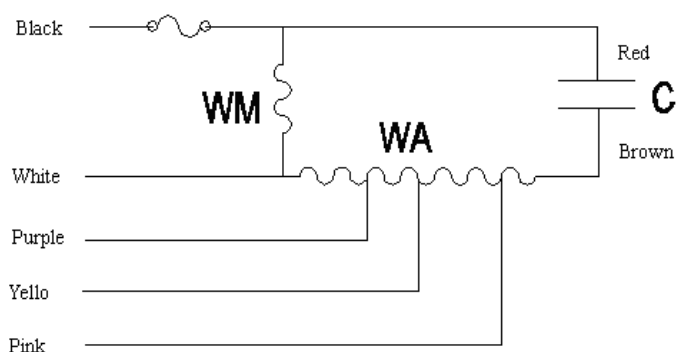

### 3. Transformers (Model:TDA-3-02FY) Electrical

Item	Red—Red	White—White
DCR	175±20%	≤4
No-load characteristics	≤50mA	17.5±5%
Load Characteristics		15±5%

### 4. Resistance characteristics of the sensor

① Thermistor 1326150 (Inner), 1205710 (Inner Coil), 1326145 (Outer), 1201121 (Outer coil) Standard Resistance Characteristics

Temp	Center	Temp	Center	Temp	Center	Temp	Center
-30	63.513	20	6.0836	70	1.0716	120	0.2708
-29	60.135	21	5.8467	71	1.0395	121	0.2642
-28	56.956	22	5.6205	72	1.0085	122	0.2577
-27	53.963	23	5.4043	73	0.9786	123	0.2514
-26	51.144	24	5.1976	74	0.9497	124	0.2452

-25	48.488	25	5.0000	75	0.9217	125	0.2393
-24	45.985	26	4.8110	76	0.8947	126	0.2335
-23	43.627	27	4.6302	77	0.8686	127	0.2278
-22	41.403	28	4.4572	78	0.8434	128	0.2224
-21	39.305	29	4.2916	79	0.8190	129	0.2170
-20	37.326	30	4.1331	80	0.7954	130	0.2118
-19	35.458	31	3.9813	81	0.7726	131	0.2068
-18	33.695	32	3.8359	82	0.7506	132	0.2019
-17	32.030	33	3.6966	83	0.7292	133	0.1971
-16	30.458	34	3.5632	84	0.7086	134	0.1924
-15	28.972	35	3.4532	85	0.6886	135	0.1879
-14	27.567	36	3.3125	86	0.6693	136	0.1835
-13	26.239	37	3.1949	87	0.6506	137	0.1792
-12	24.984	38	3.0821	88	0.6325	138	0.1750
-11	23.795	39	2.9738	89	0.6149	139	0.1710
-10	22.671	40	2.8699	90	0.5979	140	0.1670
-9	21.606	41	2.7702	91	0.5815	141	0.1631
-8	20.598	42	2.6744	92	0.5656	142	0.1594
-7	19.644	43	2.5825	93	0.5501	143	0.1557
-6	18.739	44	2.4942	94	0.5352	144	0.1522
-5	17.881	45	2.4093	95	0.5207	145	0.1487
-4	17.068	46	2.3278	96	0.5066	146	0.1453
-3	16.297	47	2.2495	97	0.4930	147	0.1420
-2	15.565	48	2.2741	98	0.4798	148	0.1388
-1	14.871	49	2.1017	99	0.4670	149	0.1357
0	14.212	50	2.0321	100	0.4546	150	0.1326
1	13.586	51	1.9651	101	0.4426		
2	12.991	52	1.9006	102	0.4309		
3	12.426	53	1.8385	103	0.4196		
4	11.888	54	1.7788	104	0.4086		
5	11.378	55	1.7213	105	0.3980		
6	10.893	56	1.6660	106	0.3876		
7	10.431	57	1.6127	107	0.3776		
8	9.9912	58	1.5613	108	0.3679		
9	9.5727	59	1.5119	109	0.3584		
10	9.1743	60	1.4642	110	0.3493		
11	8.7948	61	1.4182	111	0.3403		
12	8.4332	62	1.3639	112	0.3317		
13	8.0086	63	1.3312	113	0.3233		
14	7.7602	64	1.2900	114	0.3151		
15	7.4470	65	1.2503	115	0.3072		
16	7.1482	66	1.2120	116	0.2995		
17	6.8632	67	1.1750	117	0.2920		
18	6.5912	68	1.1393	118	0.2848		

19	6.3315	69	1.1049	119	0.2777		
----	--------	----	--------	-----	--------	--	--

② Thermistor 1201219(RZA-0-5259-090-XX-0(Exhaust) ) Standard Resistance Characteristics

R(0)=187.25K	Resistor divider: 6.8K		
T(°C)	R(K)	AD	U(V)
-20	526.61	13	0.0635
-19	497.84	14	0.0684
-18	470.87	15	0.0732
-17	445.57	15	0.0732
-16	421.83	16	0.0781
-15	399.54	17	0.083
-14	378.61	18	0.0879
-13	358.96	19	0.0928
-12	340.48	20	0.0977
-11	323.11	21	0.1025
-10	306.77	22	0.1074
-9	291.4	23	0.1123
-8	276.92	25	0.1221
-7	263.29	26	0.127
-6	250.44	27	0.1318
-5	238.33	28	0.1367
-4	226.91	30	0.1465
-3	216.13	31	0.1514
-2	205.95	33	0.1611
-1	196.34	34	0.166
0	187.25	36	0.1758
1	178.66	38	0.1855
2	170.53	39	0.1904
3	162.84	41	0.2002
4	155.56	43	0.21
5	148.66	45	0.2197
6	142.12	47	0.2295
7	135.93	49	0.2393
8	130.03	51	0.249
9	124.45	53	0.2588
10	119.14	55	0.2686
11	114.1	58	0.2832
12	109.31	60	0.293
13	104.75	62	0.3027
14	100.42	65	0.3174
15	96.289	68	0.332
16	92.358	70	0.3418

17	88.612	73	0.3564
18	85.042	76	0.3711
19	81.637	79	0.3857
20	78.388	82	0.4004
21	75.287	85	0.415
22	72.326	88	0.4297
23	69.498	91	0.4443
24	66.795	95	0.4639
25	64.21	98	0.4785
26	61.739	102	0.498
27	59.373	105	0.5127
28	57.11	109	0.5322
29	54.942	113	0.5518
30	52.866	117	0.5713
31	50.876	121	0.5908
32	48.939	125	0.6104
33	47.14	129	0.6299
34	45.386	133	0.6494
35	43.703	138	0.6738
36	42.087	142	0.6934
37	40.536	147	0.7178
38	39.047	152	0.7422
39	37.616	157	0.7666
40	36.24	162	0.791
41	34.919	167	0.8154
42	33.648	172	0.8398
43	32.426	178	0.8691
44	31.25	183	0.8936
45	30.119	189	0.9229
46	29.03	194	0.9473
47	27.982	200	0.9766
48	26.973	206	1.0059
49	26.001	212	1.0352
50	25.065	219	1.0693
51	24.163	225	1.0986
52	23.295	231	1.1279
53	22.457	238	1.1621
54	21.65	245	1.1963
55	20.873	252	1.2305
56	20.123	259	1.2646
57	19.399	266	1.2988
58	18.702	273	1.333
59	18.029	280	1.3672
60	17.38	288	1.4063

61	16.754	296	1.4453
62	16.15	303	1.4795
63	15.568	311	1.5186
64	15.005	319	1.5576
65	14.463	327	1.5967
66	13.939	336	1.6406
67	13.433	344	1.6797
68	12.946	353	1.7236
69	12.475	361	1.7627
70	12.02	370	1.8066
71	11.581	379	1.8506
72	11.158	388	1.8945
73	10.749	397	1.9385
74	10.354	406	1.9824
75	9.9733	415	2.0264
76	9.6055	424	2.0703
77	9.2505	434	2.1191
78	8.9078	443	2.1631
79	8.577	453	2.2119
80	8.2577	462	2.2559
81	7.9495	472	2.3047
82	7.652	482	2.3535
83	7.3649	492	2.4023
84	7.0878	501	2.4463
85	6.8204	511	2.4951
86	6.5623	521	2.5439
87	6.3133	531	2.5928
88	6.0731	541	2.6416
89	5.8413	551	2.6904
90	5.6177	561	2.7393
91	5.4018	571	2.7881
92	5.1939	581	2.8369
93	4.9932	590	2.8809
94	4.7997	600	2.9297
95	4.6131	610	2.9785
96	4.4331	620	3.0273
97	4.2596	630	3.0762
98	4.0924	639	3.1201
99	3.9312	649	3.1689
100	3.7759	658	3.2129
101	3.6262	668	3.2617
102	3.4819	677	3.3057
103	3.3429	687	3.3545
104	3.209	696	3.3984

105	3.0801	705	3.4424
106	2.9559	714	3.4863
107	2.8363	723	3.5303
108	2.7211	731	3.5693
109	2.6103	740	3.6133
110	2.5036	748	3.6523
111	2.4009	757	3.6963
112	2.3021	765	3.7354
113	2.207	773	3.7744
114	2.1155	781	3.8135
115	2.0276	789	3.8525
116	1.943	796	3.8867
117	1.8616	804	3.9258
118	1.7834	811	3.96
119	1.7082	818	3.9941
120	1.6359	825	4.0283



## 8.4 Failure Analysis Process:

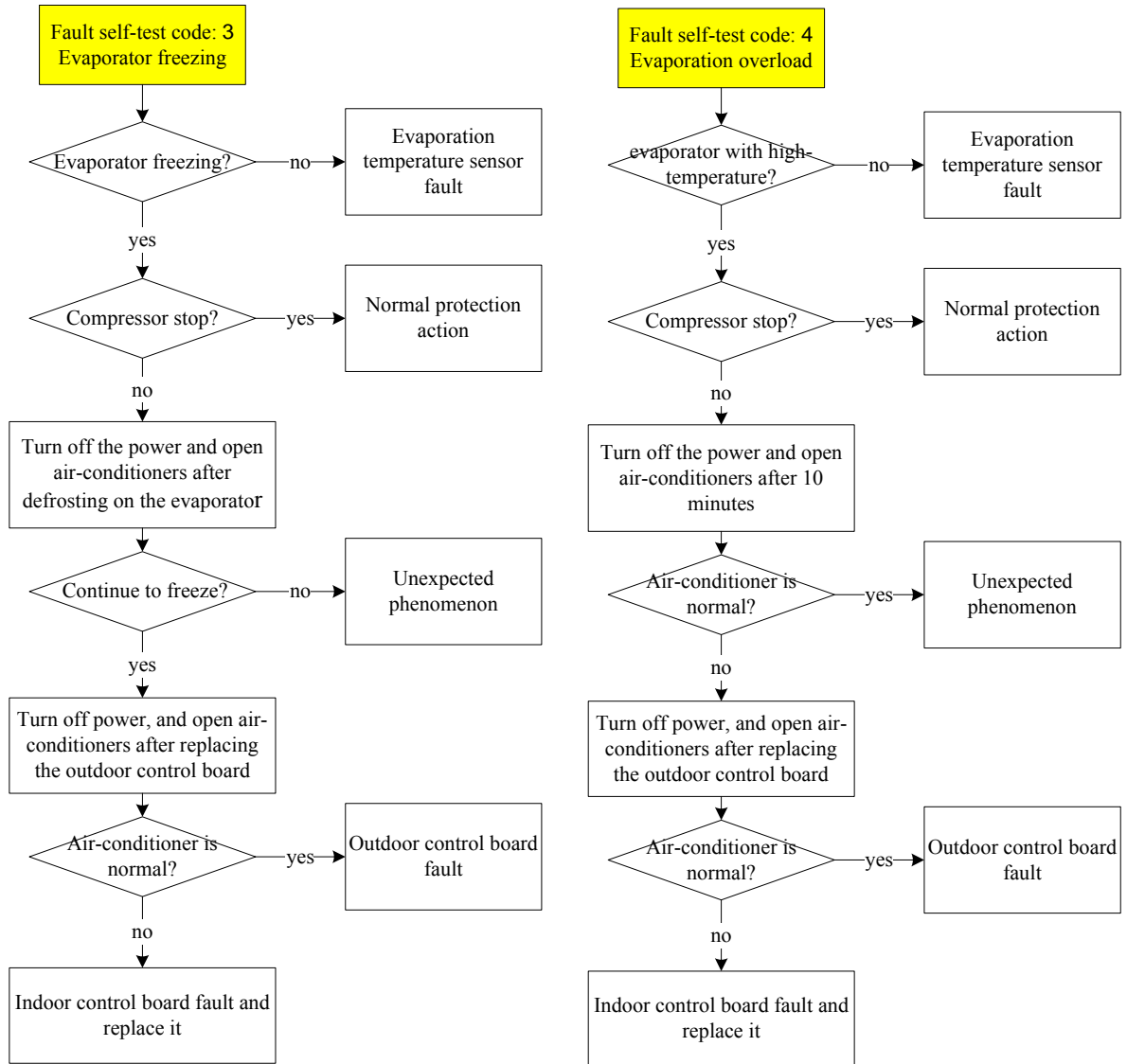

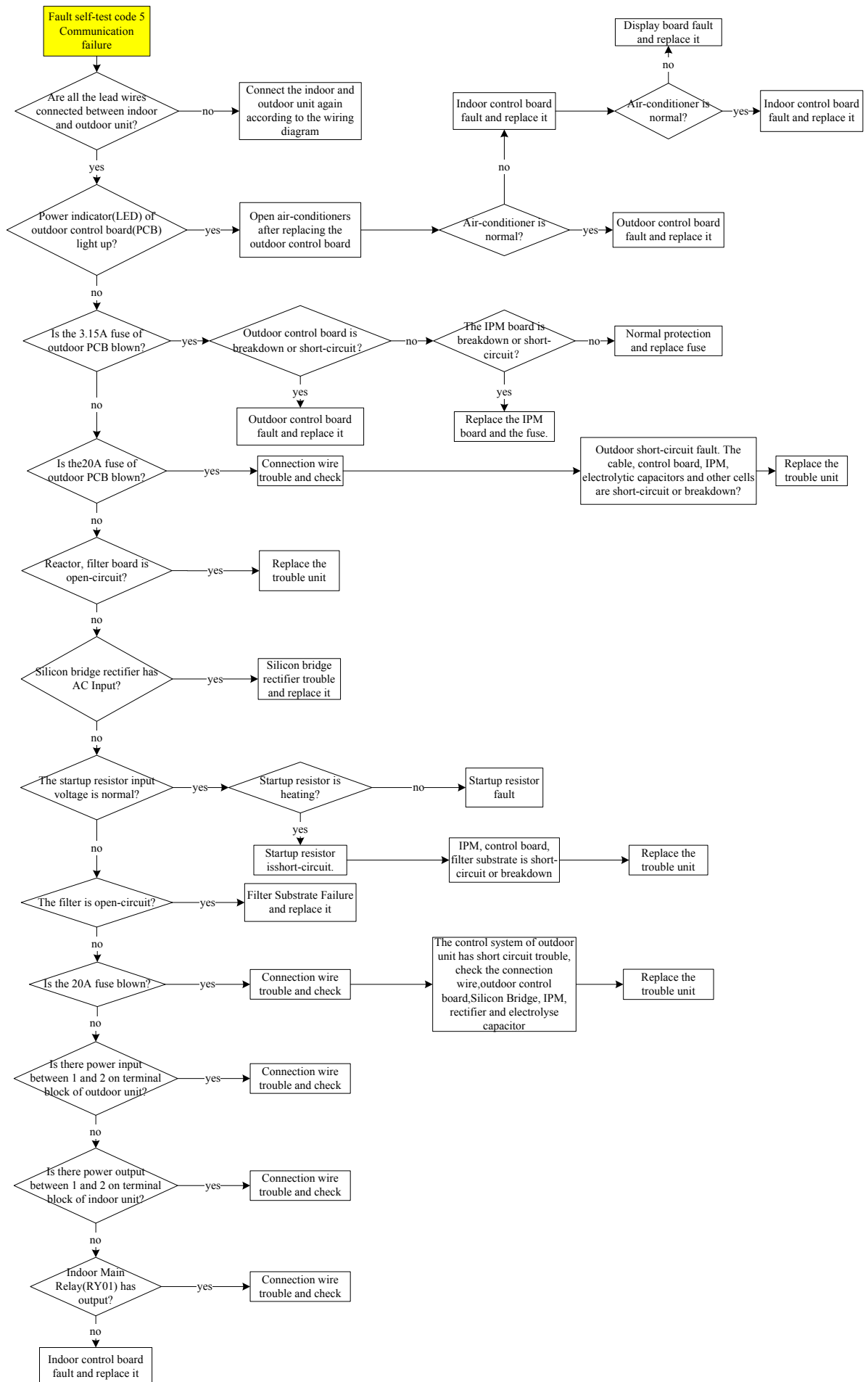

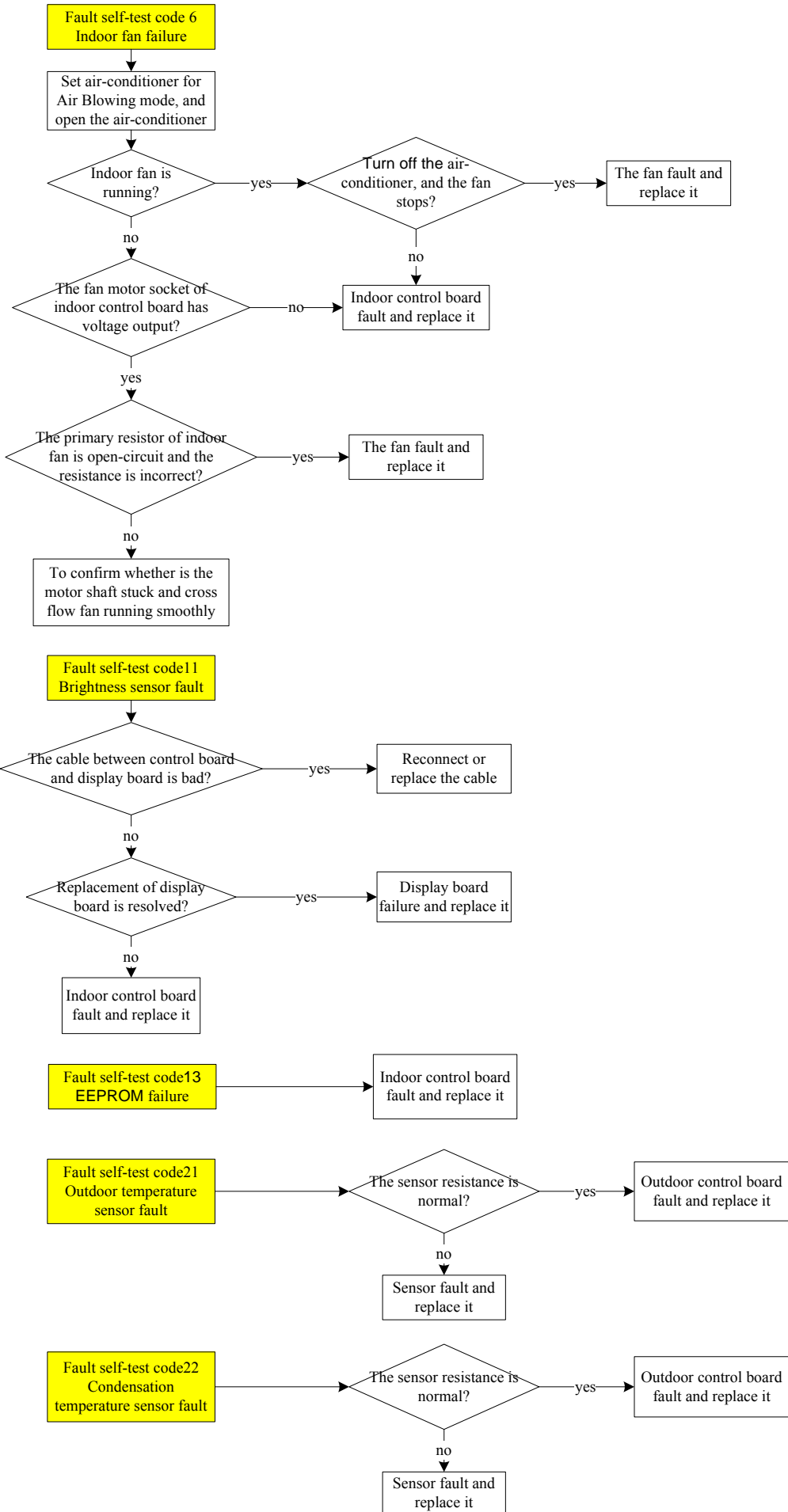

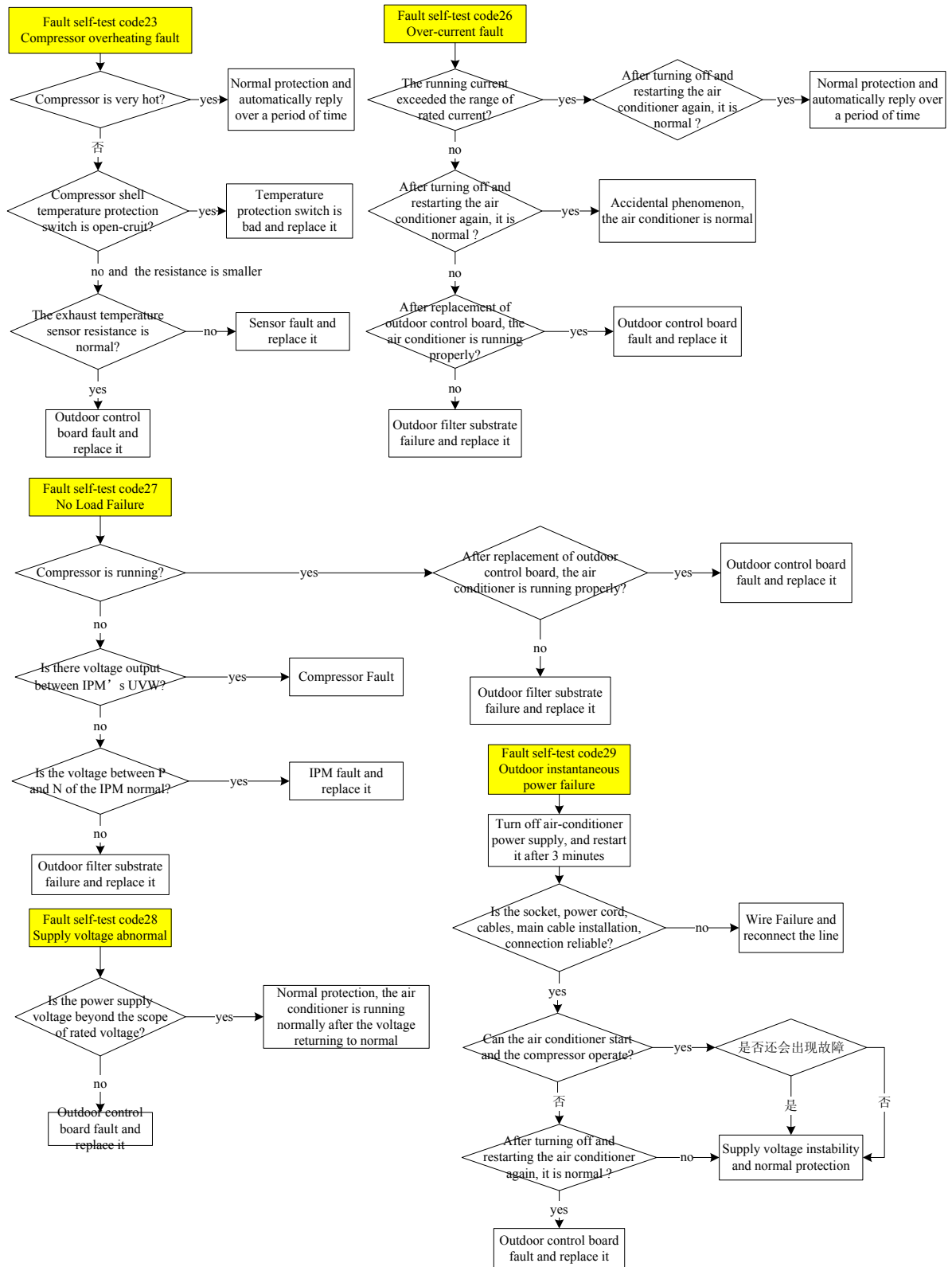

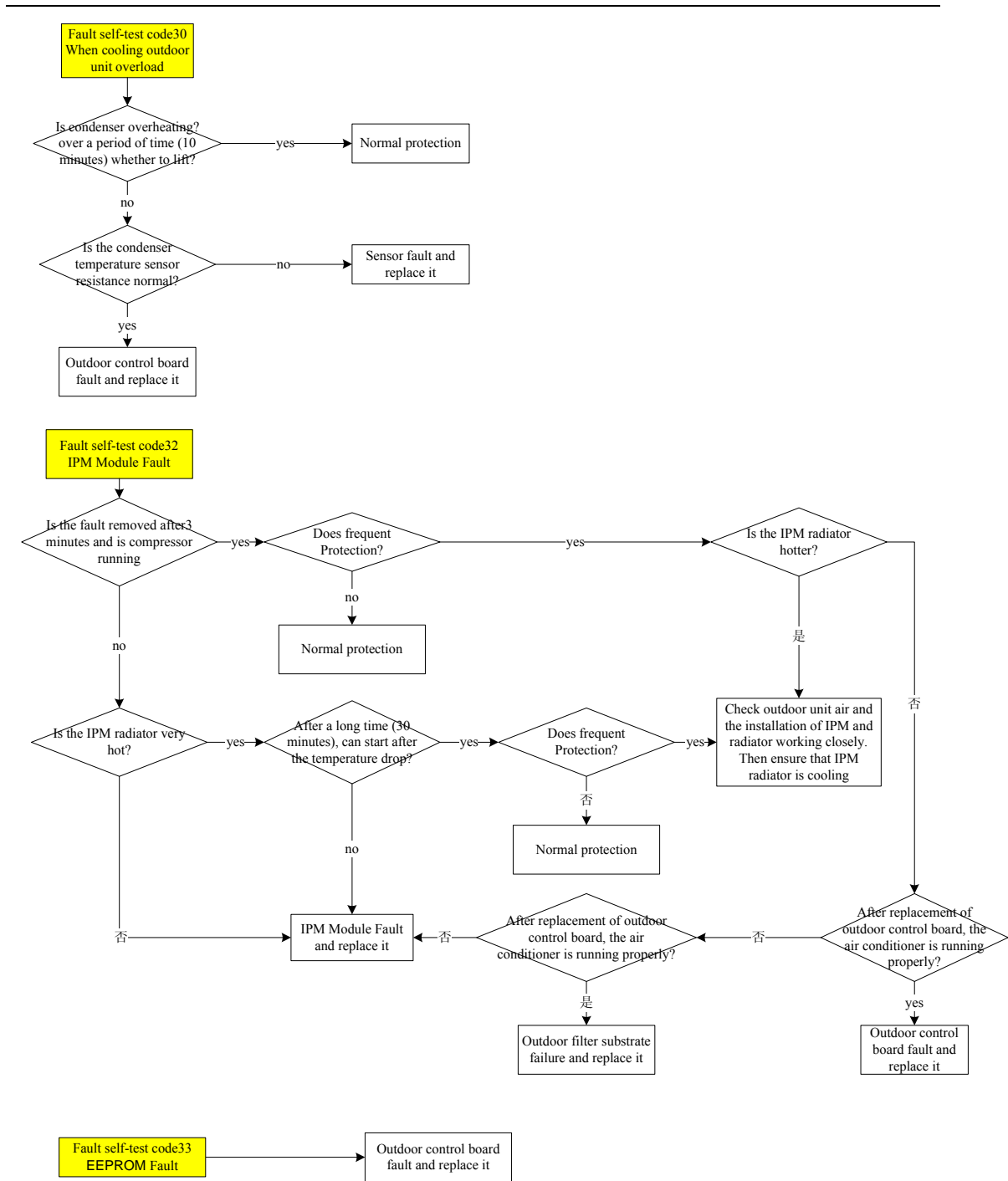

Большая библиотека технической документации  
<http://splitoff.ru/tehn-doc.html>  
 каталоги, инструкции, сервисные мануалы, схемы.